

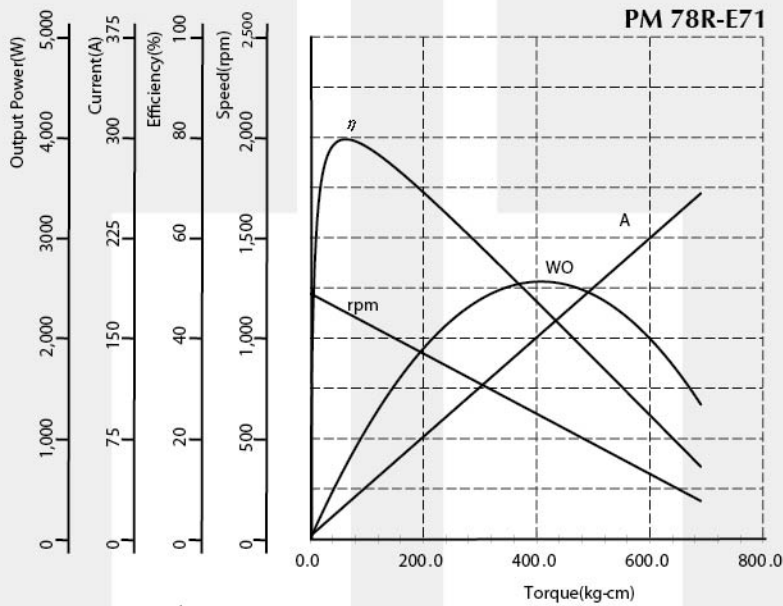

## Industrial PMDC Motor - PM78R Series

Voltage : 36 - 230V DC  
 Rated Speed : 500 - 2,800rpm  
 Rated Torque : 65.42 - 97.20kg-cm[56.78 - 84.37lb-in]  
 Rated Input Power : 350 - 3,000W  
 Insulation Class : A, E, B  
 Motor Diameter :  $\varnothing$ 194.3mm[7.65inch]  
 Typical Application : Floor Polisher

### Performance Curve



### Dimension (mm[inch])

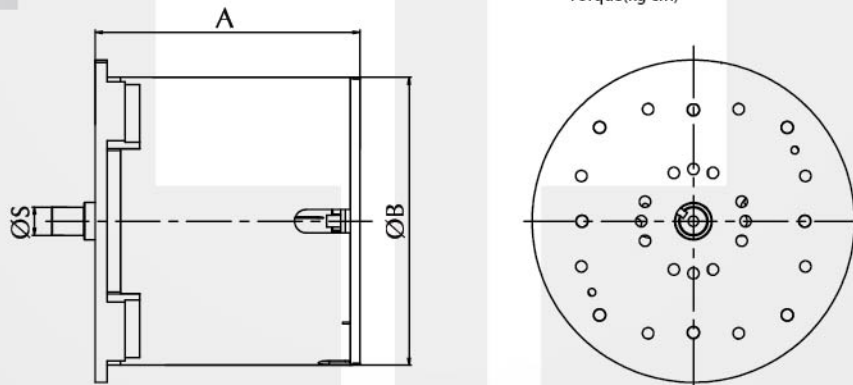

### Performance (testing under room temperature)

Model	Dim A mm[inch]	Dim B mm[inch]	Dim S mm[inch]	Rated Voltage (V DC)	No Load		At Maximum Efficiency				Maximum Power			
					Speed (rpm)	Current (A)	Speed (rpm)	Current (A)	Torque (kg-cm[lb-in])	Output (W)	Speed (rpm)	Current (A)	Torque (kg-cm[lb-in])	Output (W)
<b>PM78R-E71</b>	196.0[7.72]	194.3[7.65]	15.0[0.59]	36	1,223	2.11	1,125	26.37	65.42[56.78]	755.82	611	154.14	408[354.30]	2,560
<b>PM78R-E7R</b>	177.5[6.99]	194.3[7.65]	15.0[0.59]	230	2,240	1.10	2,087	13.34	97.20[84.37]	2,083.25	1119	74	712[617.99]	8,182.06

The information above is for reference only, detailed specification is subject to final confirmation

Email: sales@cclmotors.com Website: <http://www.cclmotors.com>  
4/F, No. 6, On Lok Mun Street, On Lok Tsuen, Fanling, N.T., Hong Kong.

Tel: (852) 3125 0000 Fax: (852) 3125 0125