

Transaxle - GT66S-09 Series

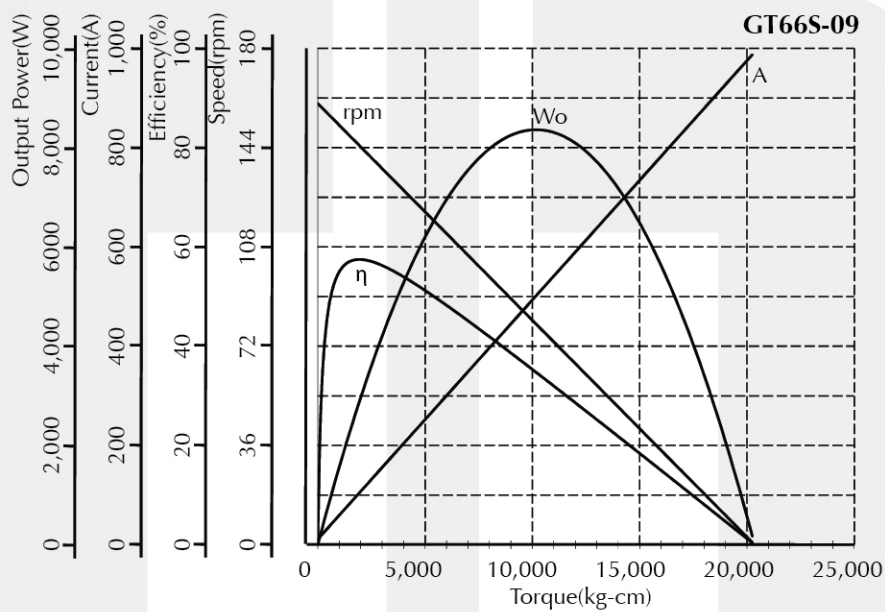

Voltage : 48V DC
 Rated Speed : 100 - 200rpm
 Rated Output Power: 1,200 - 2,300W
 Gear Ratio : 17.25:1
 Rated Torque : 750 - 1,490kg-cm[651.0 - 1,293.3lb-in]
 Loading Capability : 10,605kg-cm [9,205.14lb-in]
 Motor Diameter : $\varnothing 171.0\text{mm}$ [6.73inch]
 Typical Application : Scooter, Material Hauling Cart

Performance Curve



Dimension (mm[inch])

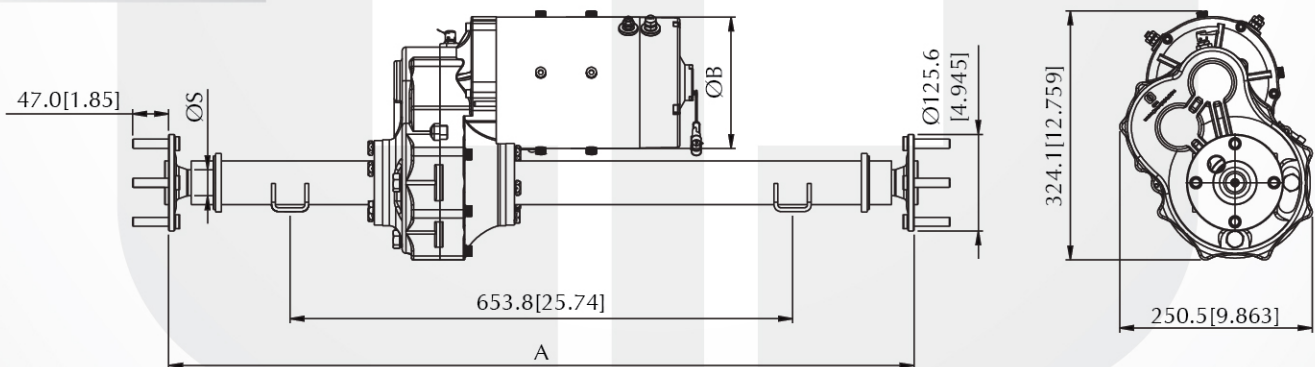

Performance (testing under room temperature)

Model	Dim A mm[inch]	Dim B mm[inch]	Dim S mm[inch]	Gear Ratio	Rated Voltage (V DC)	No Load		At Maximum Efficiency				Max Power		
						Speed (rpm)	Current (A)	Torque (kg-cm[lb-in])	Speed (rpm)	Current (A)	Output (W)	Effic'y (%)	Torque (kg-cm[lb-in])	Current (A)
GT66D-09	969.8[24.43]	171[6.73]	34[1.34]	17.25:1	48	160	11	1,908[1656.14]	145	103	2,854	57.5	10,605[9,205.14]	530

The information above is for reference only, detailed specification is subject to final confirmation

Email: sales@cclmotors.com Website: <http://www.cclmotors.com>
4/F, No. 6, On Lok Mun Street, On Lok Tsuen, Fanling, N.T., Hong Kong.

Tel: (852) 3125 0000 Fax: (852) 3125 0125