

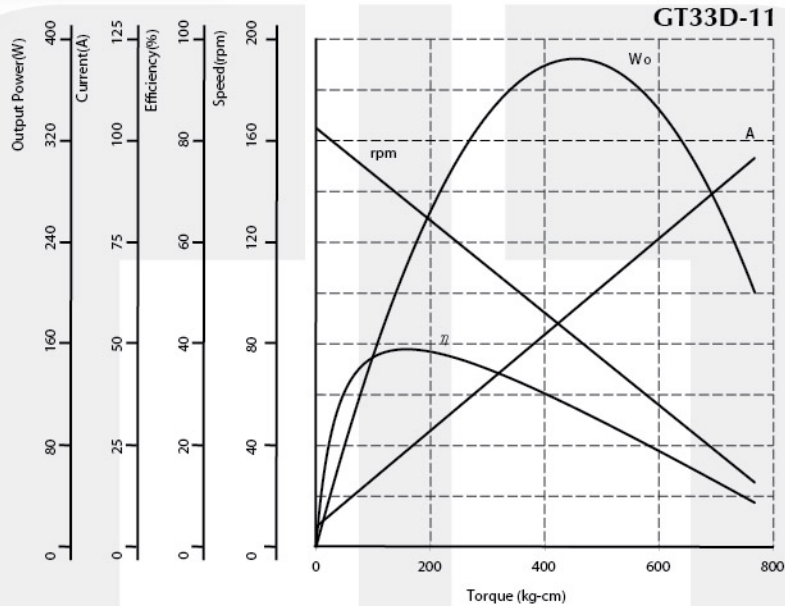

Transaxle - GT33D-11 Series

Voltage : 12 - 48V DC
 Rated Speed : 80 - 150rpm
 Rated Output Power: 150 - 250W
 Gear Ratio : 18 : 1
 Rated Torque : 163.0kg-cm[141.4lb-in]
 Loading Capability : 453.0kg-cm[392.8lb-in]
 Motor Diameter : Ø83.8mm[3.3inch]
 Typical Application : Scooter, Sweeper, Golf Cart

Performance Curve



Dimension (mm[inch])

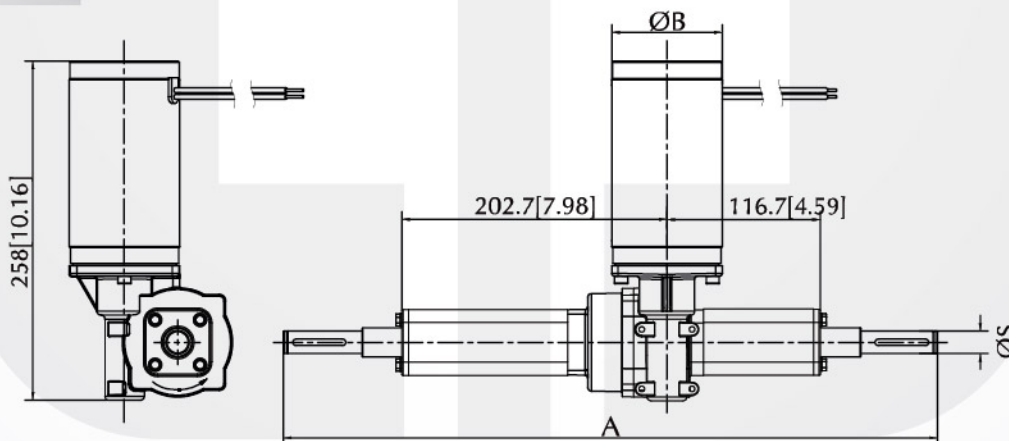

Performance (testing under room temperature)

Model	Dim A mm[inch]	Dim B mm[inch]	Dim S mm[inch]	Gear Ratio	Rated Voltage (V DC)	No Load		At Maximum Efficiency					Max Power	
						Speed (rpm)	Current (A)	Torque (kg-cm[lb-in])	Speed (rpm)	Current (A)	Output (W)	Effc'y (%)	Torque (kg-cm[lb-in])	Current (A)
GT33D-11	498[19.61]	83.8[3.3]	17[0.67]	18:1	24	165	5.0	163[141.4]	135	23	227	41.4	453[392.8]	53.5

The information above is for reference only, detailed specification is subject to final confirmation

Email: sales@cclmotors.com Website: <http://www.cclmotors.com>
4/F, No. 6, On Lok Mun Street, On Lok Tsuen, Fanling, N.T., Hong Kong.

Tel: (852) 3125 0000 Fax: (852) 3125 0125