

Induction Motor - IE Series

Voltage : 100 - 240V AC (50/60Hz)
 Rated Speed : 3,200rpm (2pole), 1,400rpm (4pole)
 Rated Output Power: 200 - 360W
 Insulation Class : A, E, B, F
 Motor Diameter : Ø131mm[5.16inch]
 Typical Application : Food Processor, Garage Door Opener

Performance Curve

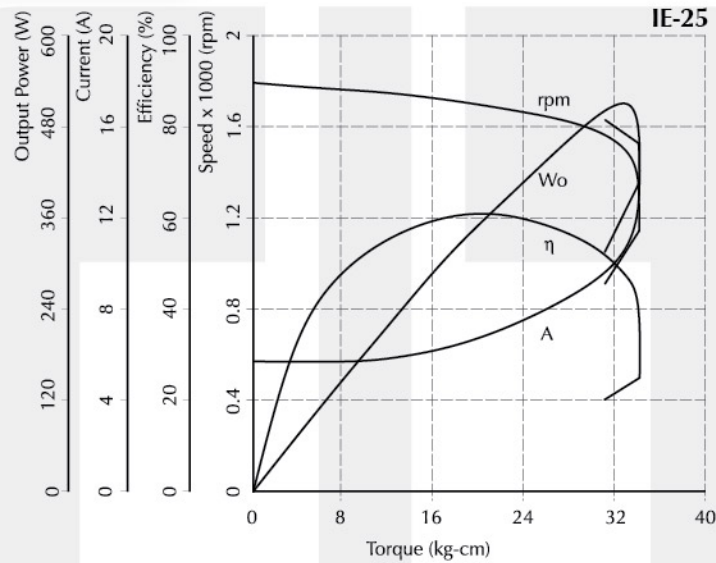

Dimension (mm[inch])

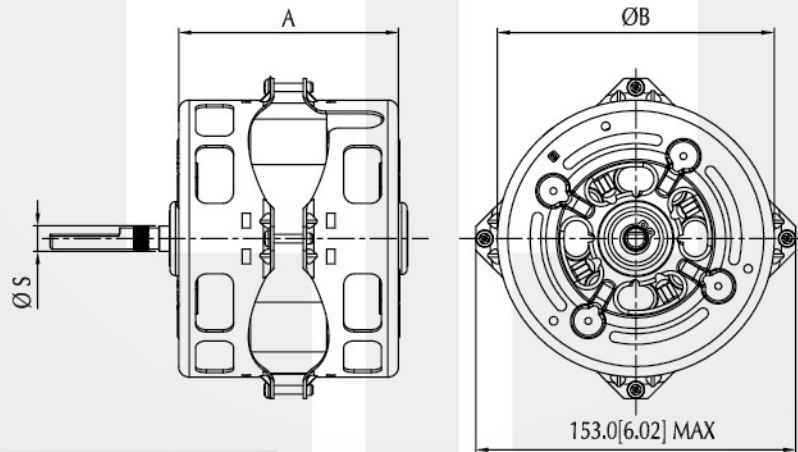

Performance (testing under room temperature)

Model	Dim A mm[inch]	Dim B mm[inch]	Dim S mm[inch]	2 Pole			4 Pole		
				Rated Input Power (W)	Rated Output Power (W)	Breakdown Torque (kg-cm[lb-in])	Rated Input Power (W)	Rated Output Power (W)	Breakdown Torque (kg-cm[lb-in])
IE-20	90 [3.54]	131 [5.16]	12 [0.47]	300	200	9.0 [7.83]	400	200	16 [13.92]
IE-25	95 [3.74]	131 [5.16]	12 [0.47]	375	250	11.0 [9.57]	500	250	20 [17.40]
IE-28	98 [3.86]	131 [5.16]	12 [0.47]	420	280	12.5 [10.88]	560	280	22 [19.14]
IE-30	100 [3.94]	131 [5.16]	12 [0.47]	450	300	13.5 [11.75]	600	300	24 [20.88]
IE-36	104 [4.09]	131 [5.16]	12 [0.47]	540	360	16.5 [14.36]	720	360	30 [26.10]

The information above is for reference only, detailed specification is subject to final confirmation