

PMDC Motor

永磁直流电机

Powertrain Management System
动力管理系统

series 系列
0106



Typical Applications 应用范围 : ETC (Electronic throttle control)
电子节气门

Features 特性 : High Temperature Endurance,
High Vibration Endurance
耐高温, 耐振动

Weight 重量 : 206(g/克)

Performance Curve 曲线图

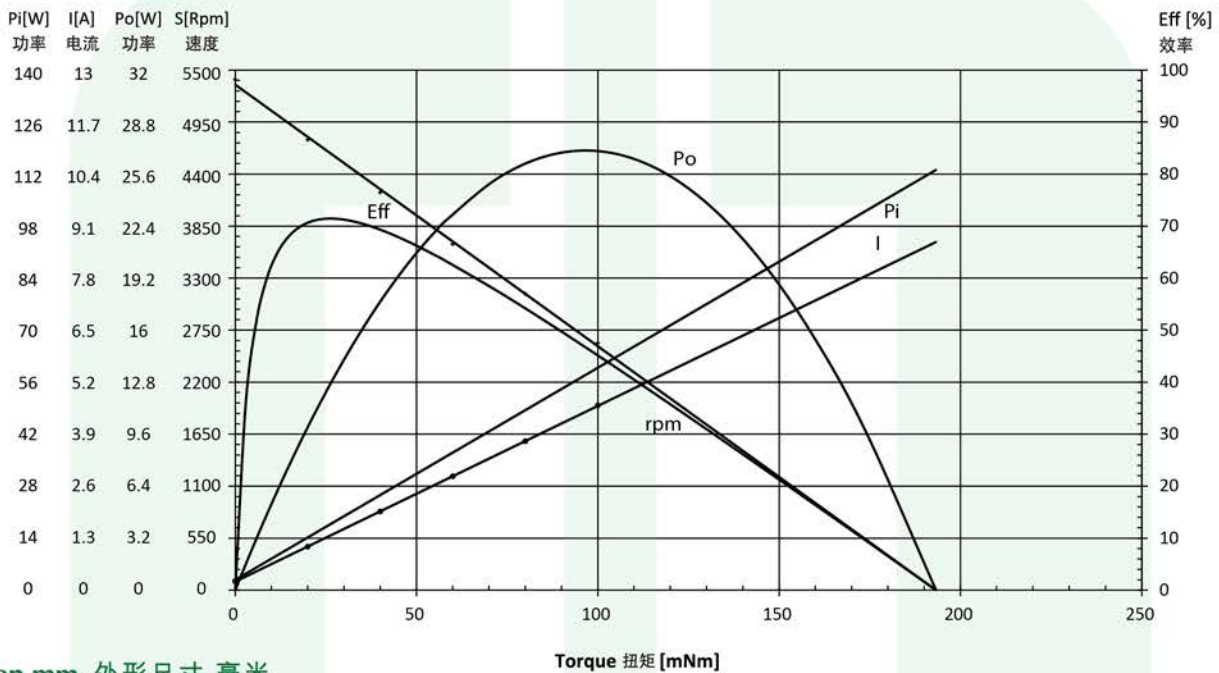

Dimension mm 外形尺寸 毫米

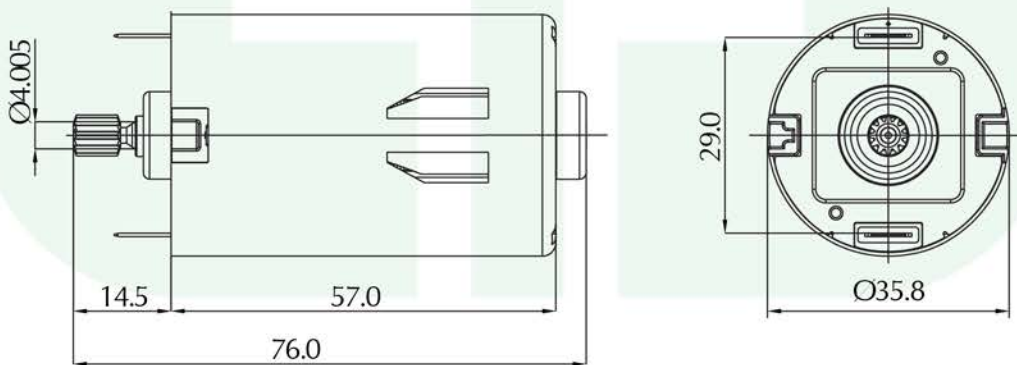

Performance (testing under room temperature) 马达性能(室内温度测度结果)

Model 产品类型	Motor Performance 电机性能											Motor Characteristics 电机特性						
	Voltage 电压		No Load 空载		Stall 堵转		Maximum Efficiency 最高效率				Maximum Power 最大功率			Torque Constant [mNm/A]	Speed Constant [rpm/mNm]			
	Rated 电压 [V]	Operating 电压 [V]	Speed 转速 [rpm]	Current 电流 [A]	Torque 扭矩 [mNm]	Current 电流 [A]	Torque 扭矩 [mNm]	Speed 转速 [rpm]	Current 电流 [A]	Power 功率 [W]	Eff 效率 [%]	Torque 扭矩 [mNm]	Speed 转速 [rpm]			Current 电流 [A]	Power 功率 [W]	Eff 效率 [%]
01060726003	13	9-17	5,396	0.23	188	8.5	26.5	4,637	1.39	12.9	71.1	94.2	2,698	4.37	26.6	54.2	22.8	26.7

This product catalogue is subject to copyright owned by the limited. Any reproduction, adaptation, distribution, dissemination or making available of such copyright works to the public is strictly prohibited. All product information is for reference only, detailed specification is subject to final confirmation.

产品资料乃授本公司之版权保护。任何复制或、改编、分发、发布或提供该等版权之资料向公众是严格禁止的。所有产品信息仅供参考，详细规格以最后确认为准。