

PMDC Motor

永磁直流电机

Powertrain Management System
动力管理系统

series 系列
0103



Typical Applications 应用范围 : EWGA
(Electric Waste Gate Actuator)
废气门电控执行器

Features 特性 : High Temperature Endurance
耐高温

Weight 重量 : 133.5(g/克)

Performance Curve 曲线图

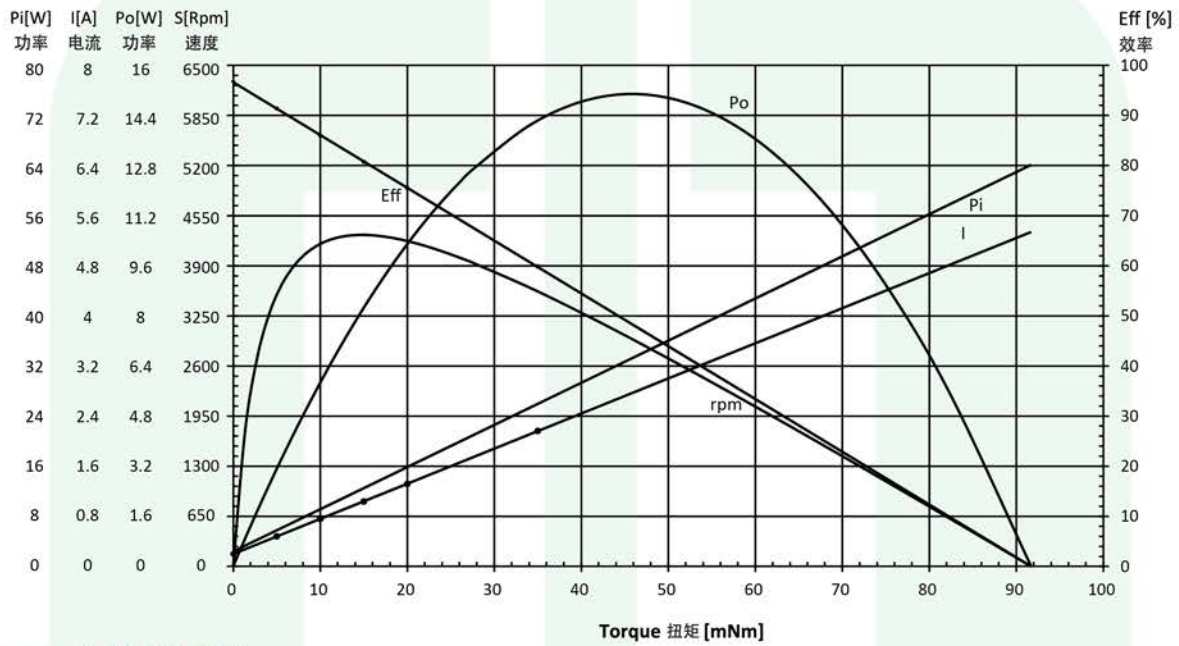

Dimension mm 外形尺寸 毫米

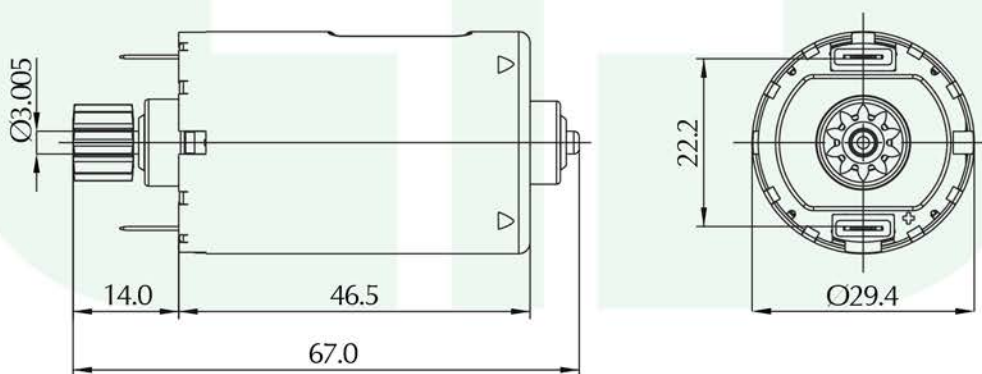

Performance (testing under room temperature) 马达性能(室内温度测度结果)

Model 产品类型	Motor Performance 电机性能															Motor Characteristics 电机特性		
	Voltage 电压		No Load 空载		Stall 堵转		Maximum Efficiency 最高效率					Maximum Power 最大功率					Torque Constant [mNm/A]	Speed Constant [rpm/mNm]
	Rated 电压 [V]	Operating 电压 [V]	Speed 转速 [rpm]	Current 电流 [A]	Torque 扭矩 [mNm]	Current 电流 [A]	Torque 扭矩 [mNm]	Speed 转速 [rpm]	Current 电流 [A]	Power 功率 [W]	Eff 效率 [%]	Torque 扭矩 [mNm]	Speed 转速 [rpm]	Current 电流 [A]	Power 功率 [W]	Eff 效率 [%]		
01030524008	12	8-17	6,292	0.2	91.7	5.34	14.8	5,269	1.03	12.3	66.2	45.9	3,141	2.77	33.2	45.4	17.8	68.5

This product catalogue is subject to copyright owned by the limited. Any reproduction, adaptation, distribution, dissemination or making available of such copyright works to the public is strictly prohibited. All product information is for reference only, detailed specification is subject to final confirmation.

产品资料乃授本公司之版权保护。任何复制、改编、分发、发布或提供该等版权之资料向公众是严格禁止的。所有产品信息仅供参考，详细规格以最后确认为准。